

MPS 010 FA - Combo | STA 1 + CX 2ex

The Carton Sealing and Strapping machine is a packaging machine which integrates the function of sealing and strapping cartons automatically; it can be equipped in automatic packaging line, seal tapes on the top and bottom, strap machine with several belts, and improve the automatic packaging degree in the end line. It is of high efficiency, and widely applied in mass production industries like toys, home appliances, printing pharmaceuticals, electronics, daily necessities, etc.

- Sealing and strapping can be operated at same time, high speed, high efficiency and place saving;
- Controlled by PLC, easy to operate and low failure rate
- Imported sensor is adopted to ensure accurate, strapping can automatically do 1-3 line strapping
- Can be used in stand-alone; high capability and low price.



Specifications

| | |
|----------------------------|--|
| Power Supply | 3Ø, 380V, 50 Hz, 1.5 Kw |
| Belt Speed (Carton Sealer) | 20 Meters / Min. |
| Packaging Speed | 8 Cartons/Min. |
| Packaging Size | L-300~700 X W-200~500 X 150~500mm |
| Carton Weight | 5-40 Kgs |
| PP Strap | 9/12/15mm - to be specified at the time of placing the order |
| Tension Adjustment | 5~70 Kgf |
| Adhesive Tape | 48 / 60 / 72 mm |
| Machine Weight | 450 Kgs |
| Machine Dimension | Please refer Drawings attached |

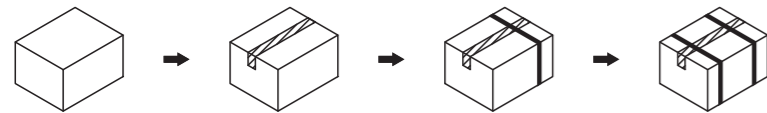
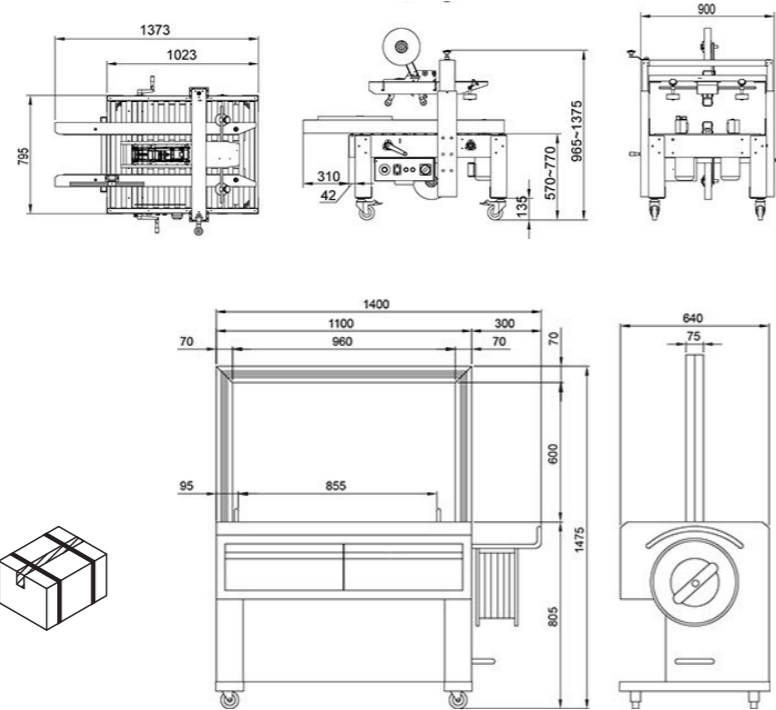

OTHER PACKAGING MACHINES



PACKAGING CONSUMABLES



Corporate Office : N-26, Site-V,
Kasna Industrial Area, Greater Noida - 201306
P : +91 120 3623882
Sales Enquiry : +91 97112 11568
Service Helpline : +91 97112 11569
E : sales@milleniumpackaging.in | W : www.milleniumpackaging.in



Note :Accessories shown in the pictures may not be the part of standard equipment.
The Company follows an ongoing process of continuous product development and upgrading the equipments, hence reserves the right to alter the specifications at any time without prior notice.
Actual machine may differ from the pictures shown in the catalogue.



Elevate Your Packaging,
Quick, Consistent, Effective.



FULLY
AUTOMATIC
STRAPPING
MACHINES

www.milleniumpackaging.in



PLC CONTROLLED



NON-CONTACT TYPE SENSORS



MODULAR ALUMINIUM ARCH



MPS 010 FA | STA1



CONTROL PANEL



HEAVY DUTY COMPONENTS FOR LONG LASTING TROUBLE FREE OPERATIONS

Specifications

| | |
|-------------------|---|
| Arch Size | 850W x 400/600H mm (Standard) |
| Power Supply | 3Ø, 380V, 50 Hz, 1250 watts |
| Strap Cycle Speed | 27 Cycles per Min |
| Tension Strength | Max. 70 Kgs. (Adjustable-Mechanically) |
| Strap Width | 9/12/15 mm - to be specified at the time of placing the order |
| Sealing Method | Heat Sealing |
| Dimension | 1400W x 640D x 1475H mm |
| Table Height | 805 mm |
| Machine Weight | 220 Kgs. |
| Gross Weight | 265 Kgs. |
| Control | PLC Controlled |

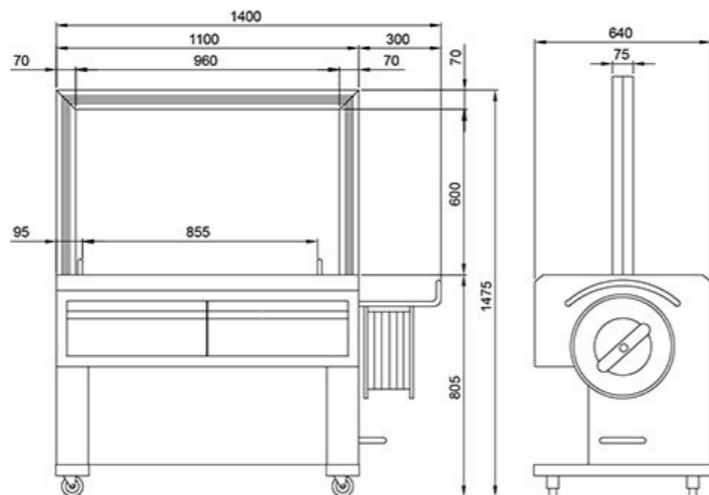

PLC Controlled

Makes the Machine reliable as compared to other Machines available in the Market using contactors & relays. Results into better longevity, lesser breakdowns and increased productivity.

3rd Generation Aluminum Alloy Arch Modular Design

Modular designed Aluminum alloy arch, easy to assemble and disassemble, Change size economical, No Arch motor required.

User Friendly

Auto strap positioning and retry feeding functions ; to ensure that the strap reaches its proper position and every cycle is accurate and efficient. Convenient operating modes with panel, ball switch and foot pedal switch.

Easy Tension Adjustment

By rotation of mechanical tension knob user can easily set required tension.

Safety Design

Control Voltage of 24V(DC) ensures the safe operation and prevents operators from electrical shock.

MPS 010 FA | 85 PRU

Strapping Machine - Standard Power Roller Table

- Standardized power roller table model with 2 sets of photocell
- Optional straps No. is available for 1, 2 or no strapping on the packages. More straps application is also available as an option before order is fixed.
- This model can incorporate with input and output conveyors as a strapping system. The control system of conveyors can be connected with this model.
- An optional photocell to control the table transmitting is available, which can auto-stop the table when no package is input.
- Equipped with Table Roller Cover.

| | | | |
|-------------------|---|------------------|-------------------------|
| Arch Size | 850W x 600H mm (Standard) | Dimension | 1550W x 800D x 1470H mm |
| Power Supply | 110/220V 50/60Hz 1Ph; 220/380V 50/60Hz 3Ph | Table Height | 810 mm |
| Strap Cycle Speed | 2.5 Sec./Cycle | Package Size | 300~820W, 30~560H mm |
| Tension Strength | Max. 70 Kgs. | Machine Weight | 330 Kgs. |
| Strap Width | 9~15.5mm | Gross Weight | 430 Kgs. |
| Sealing Method | Heat Sealing | Power Belt Speed | 15M/50Hz Per Min. |



MPS 010 FA | 85 PBU

Strapping Machine - Standard Power Belt Table

- Standardized power belt table model with 2 sets of photocell.
- Optional straps No. is available for 1, 2 or no strapping on the packages. More straps application is also available as an option before order is fixed.
- This model can incorporate with input and output conveyors as a strapping system. The control system of conveyors can be connected with this model.
- An optional photocell to control the table transmitting is available, which can auto-stop the table when no package is input.

Specifications

| | |
|-------------------|---|
| Arch Size | 850W x 600H mm (Standard) |
| Power Supply | 110/220V 50/60Hz 1Ph; 220/380V 50/60Hz 3Ph |
| Strap Cycle Speed | 2.5 Sec./Cycle |
| Tension Strength | Max. 70 Kgs. |
| Strap Width | 9~15.5mm |
| Sealing Method | Heat Sealing |
| Dimension | 1550W x 640D x 1550H mm |
| Table Height | 820 mm |
| Package Size | 200~520W, 30~560H mm |
| Machine Weight | 307 Kgs. |
| Gross Weight | 402 Kgs. |
| Power Belt Speed | 17M/50Hz Per Min. |

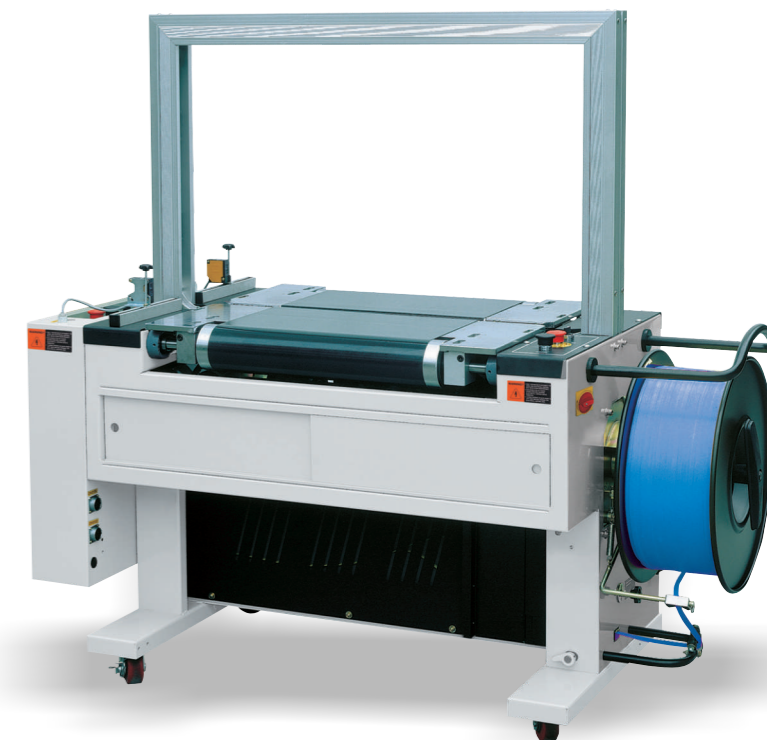

Automatic Strapping and Sealing line

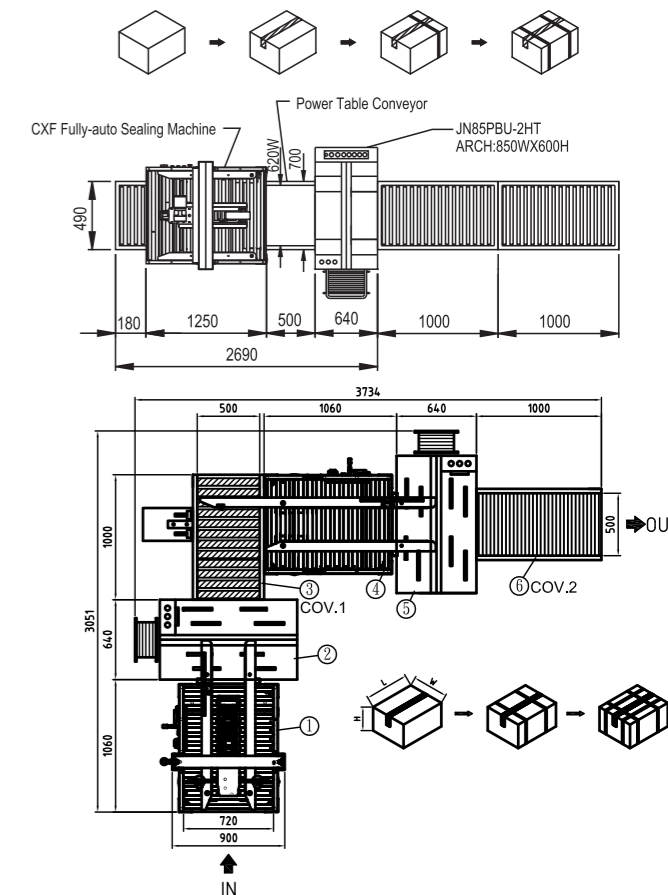
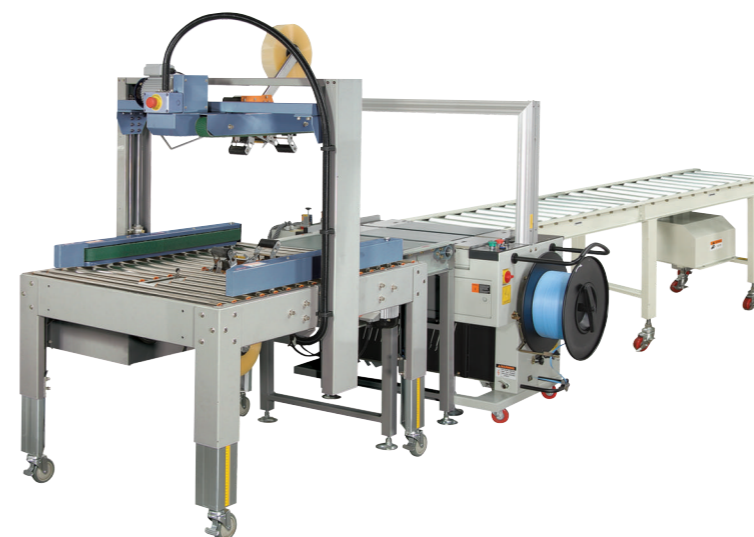

FULLY AUTOMATIC SEALING & STRAPPING LINE

PACKING SIZE: L200~500xW200~500xH110~500 MM

TABLE HEIGHT: 805MM

- CARTON SEALING MACHINE
- FULLY AUTO STRAPPING MACHINE
- POWER ROLLER CONVEYOR + 90° AIR PUSHER - L1000xW500xH805
- POWER BELT DRIVING COV - L1000xW720xH805+MICRO SWITCH
- FREE ROLLER COV - L1000xW500xH805